

Perfect, gentle and green removal of polymer and organic contaminations from metal parts & tools





APPLICATIONS

The most common application is the cleaning of dies, filters and tools in

- Synthetic fiber and nonwovens industries
- Blown and cast film production
- Polymer production
- Masterbatch production
- Extrusion
- Injection Moulding
- Packaging industry (hot melt...)
- Others

TYPICAL COMPONENTS

VACUCLEAN is especially recommended for

- Spinnerets
- Spin packs
- Nonwoven dies
- Blown film die heads
- Pelletizing dies
- Filter bundles / Filter candles
- Filter stacks / Leaf disks
- Extruder screws, screw elements
- Static mixers

ADVANTAGES

- Perfect cleaning results, even inside highly complex dies or assembled parts
- Free from carbon residues
- Easy and safe to operate
- Fully automated cleaning process
- Adjustable and slow heat-up; gentle on the materials
- Precise temperature control with direct measurement at the part
- No risk of overheating or distortion
- Only electricity and water required
- Low operating and maintenance costs
- Environmentally friendly
- Off-gas cleaning by catalytic converter
- No polluted water discharge

TYPICAL POLYMERS

- Polyolefins: PE, HDPE, PP, PB, EVA, EVOH
- Polyesters: PET, PBT, PC, PTT, PEN
- Polyamides: PA6, PA6.6, PA12, PPA
- Polyacrylates: PAN, PBA, PMA, PMMA
- Polystyrenes: PS, ABS, SB, SBS, SAN
- Biopolymers: PLA, PEA, PVAL, PPOX
- Polyetherketones: PAE, PEK, PEEK
- Polyimides: PI, PBI, PEI, PBO, PMI
- Polyurethanes: PUR, TPA, TPO, TPU, Spandex
- Special Polymers: LCP, POM, BR, NBR
- Other polymers on request

OPERATING PRINCIPLE

VACUCLEAN gently removes organic contamination from heat resistant metallic parts by melt-off and thermal decomposition under vacuum.

Cleaning time: 8 – 30 h

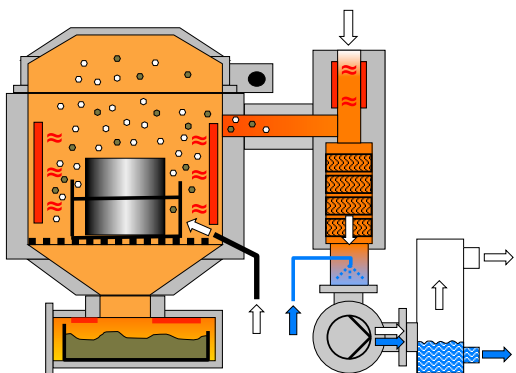
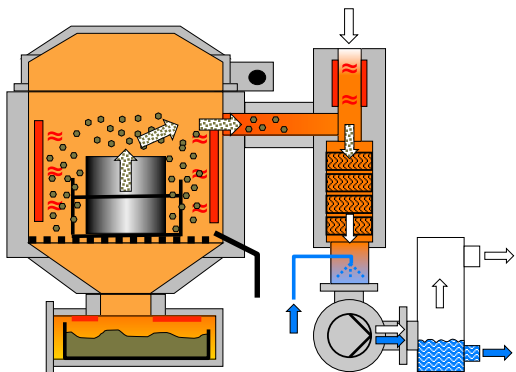
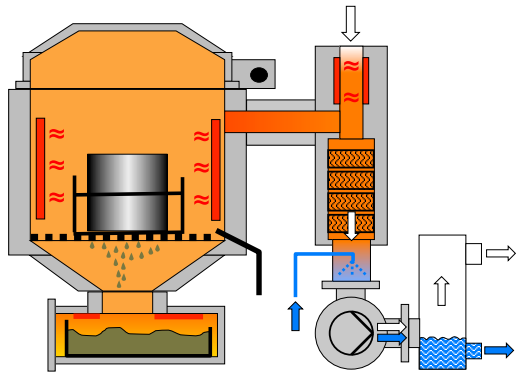

1

HEAT-UP & MELT-OFF

- Gentle heat-up of parts under vacuum
- Adjustable heat-up temperature ramp for uniform heat transfer
- Molten polymer drains into a colder melt collector.

2

PYROLYSIS

- Heat-up starts thermal decomposition process of organic contamination.
- Special control sensors protect parts and dies from temperature damage.
- Adjustable process temperatures up to 450 °C (600 °C on request for special applications)
- The whole process runs under condition of vacuum to prevent any exothermal reactions.

3

OXIDATION

- Process controlled and automated to change from pyrolysis to oxidation
- Oxidation of remaining crystalline carbon residues under reduced vacuum
- At the end of the process the chamber can be opened and unloaded immediately or after adjustable cooling.

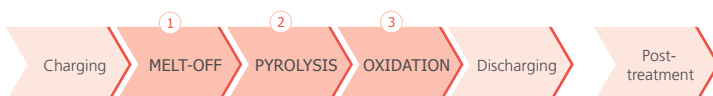

TOP LOADING SYSTEMS



VACUCLEAN 154



Catalytic converter for off-gas cleaning

VACUCLEAN 254-XH-S
(higher lid and large melt-off containers)



Process chamber of VACUCLEAN 254



VACUCLEAN 454



FRONT LOADING SYSTEMS

German Art of Engineering
since 1969



VACUCLEAN 1713-XXL with
loading / unloading platform

Process chamber and loading
pallet of VACUCLEAN 1212

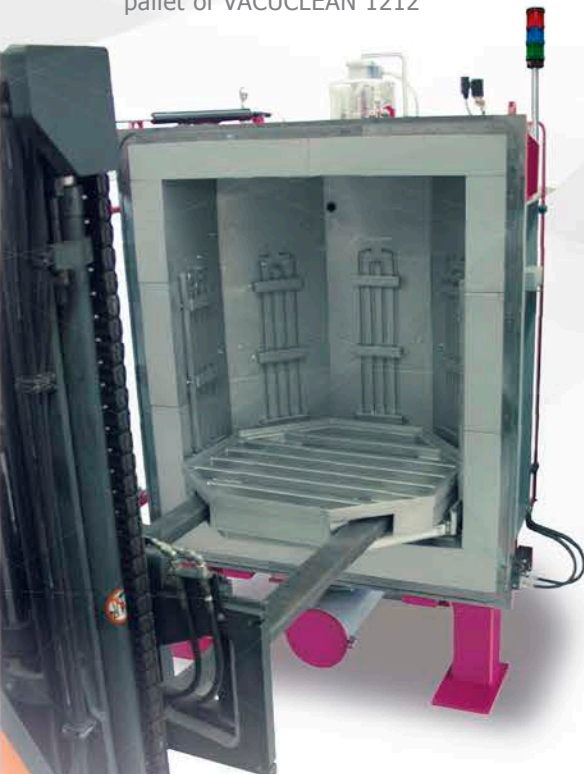

VACUCLEAN 0910



TECHNICAL DATA OF STANDARD SIZES

VACUCLEAN	COMPACT	154	254	354	454	554	654	0910	0917	1212	1713
Process chamber											
Width (mm)	500	1,120	2,180	3,230	4,280	5,340	6,400	900	900	∅ 1,250	∅ 1,700
Depth (mm)	500	530	530	530	530	530	530	900	900	–	–
Height (mm)	350	430 ¹⁾	430 ¹⁾	430 ¹⁾	430 ¹⁾	430 ¹⁾	430 ¹⁾	1,000	1,700	1,250 ¹⁾	1,300
Max. component weight (kg)	50	750	1,500	2,250	3,000	3,750	4,500	1,500	3,000	5,000 ²⁾	5,000 ³⁾
Temperature	adjustable up to 450 °C (up to 600 °C for special polymers and applications on request)										
Total dimensions (mm)											
Width (door open)	–	–	–	–	–	–	–	4,020	2,390	3,650	3,440
Width (closed)	1,220	2,600	3,410	4,270	5,320	6,380	7,430	2,280	2,400	2,620	2,880
Depth (door 90° open)	2,370	–	–	–	–	–	–	4,690	3,760	3,830	4,450
Depth (closed)	1,680	1,580	1,630	1,800	1,800	1,800	1,800	2,270	2,270	2,430	2,580
Height (lid open) ¹⁾	–	2,140	2,140	2,140	2,140	2,140	2,140	–	–	–	–
Height (lid closed)	2,150	1,350	1,350	1,350	1,350	1,350	1,350	2,220	3,420	2,940	2,980
Electrical supply											
Operating voltage	3 x 400 V / 3 x 460 V (+6% / -10%) / 50 Hz / 60 Hz										
Rated power (kW)	12/16	18/26	28/37	37/50	47/63	57/76	67/89	28/37	36/48	45/65	47/67
Average consumption (%)	30	30	30	25	25	25	25	30	30	30	30
Water supply											
Line pressure	between 3 and 6 bar										
Flow rate (m ³ /h)	0.15	0.18	0.18	0.36	0.36	0.36	0.36	0.18	0.36	0.36	0.36
Empty weight (kg)	1,100	1,430	2,050	2,400	3,000	3,600	4,200	2,700	4,500	3,450	6,880

¹⁾ Systems with higher lids and larger melt-off containers available.

²⁾ VACUCLEAN 1212-XL version: up to 7,500 kg weight.

³⁾ VACUCLEAN 1713-XXL version: up to 12,500 kg weight.

Exclusions: VACUCLEAN is NOT suitable for removing polymers containing halogens, flame retardants or combinations of chloride, fluoride, bromide, iodide (e.g. PVC, PVCA, PVDC, PTFE, PCTFE).

The data and illustrations in this brochure refer to the date of printing. All data are approximate. SCHWING reserves the right to make any necessary changes at any time and without special notice.



SCHWING Technologies North America Inc.

300 Carnegie Center Drive, Suite 150
Princeton, NJ 08540 · USA

Phone: +1 609 786-2404

E-mail: info@schwing-tech.com

www.thermal-cleaning.com

Visit us on: [f](#) [t](#) [in](#)

Information distributed by: